

DC4D 52 Documentation

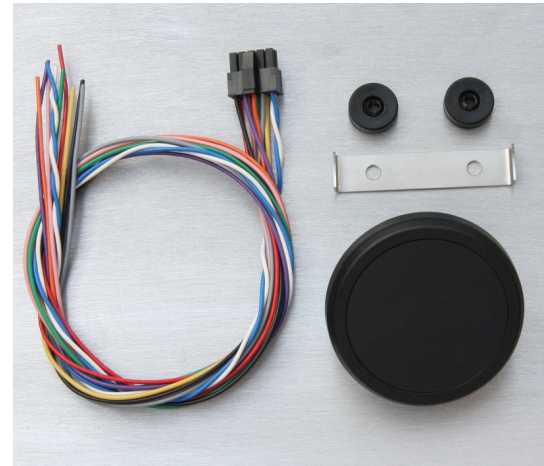

PRESENTATION

The DC4D is a display designed to display the richness information of our lambda controllers, analogue (LSU49-5V) or CAN (DigiLSU) but it can also be used for other applications.

Functionalities are same as DC4D57. Main difference is that both front panel switch are replaced by to capacitive zone touchscreen. Also, laptop communication jack connector was remove and must be add on the wiring. Rear connector is changed by a ten contact one for allowed previous functionalities.

It has 4 digits giving more resolution than its predecessor and, than most competitors.

The bargraph of sixteen LEDs provides a more dynamic interpretation of information. Three areas of color allow quickly identify if the information is in the correct range or not. A fourth color is used to identify the transition from one zone to another. The lighting of the LEDs is of the type "PWM" which gives it a more progressive display.

An ambient light sensor enables automatic adjustment of the light intensity of the display.

The presence of a CAN connection complete its performance. It therefore offers the ability to capture four information on the CAN bus and display them. Once configured, it also allows you to "digitalize" the lambda information from an analog controller and to provide richness to the ECU or datalogger with maximum precision using this CAN bus.

ELECTRICAL CHARACTERISTIQUES :

Power supply: de 7 à 16V
Consumption : 250mA maxi
Temperature use : -20°C à 60°C
Analog input : 0 à 5V
5V ouput: +/-5% max current 50mA
CAN resistance: 2kOhm
CAN Protocol: 2.0A et 2.0B

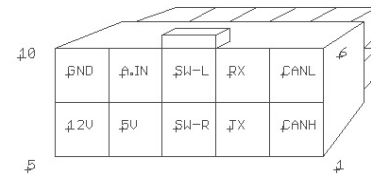
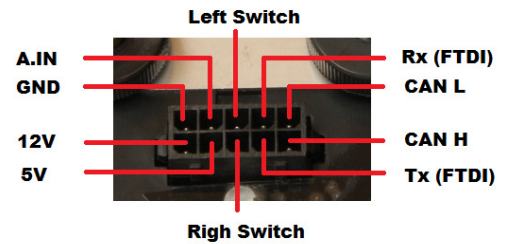

rear side connector view

MECHANICAL CHARACTERISTICS

Front : Smoked 4mm thickness Plexiglas.
Enclosure : Molded black ABS
Dimensions: Diameter 60mm; thickness 29mm (include screws)
Weight : 50 g
Main installation hole: 52mm minimum.
Max panel mount thickness : 8mm
Fixing : Rear bracket with two M4 plastic nuts.
No finished loom: Connector with ten 0.35mm² and 50cm long cables.
Connector : TE micro Mate'n'lock 10 contacts
 Ref connector loom: 1-794617-0 (Farnell: 111-1091)
 Ref contacts: 794610-1 (Farnell: 111-1151)

IP : IP63 on the front (exception for jack connector)
 IP40 on the back



ELECTRICAL CONNECTION

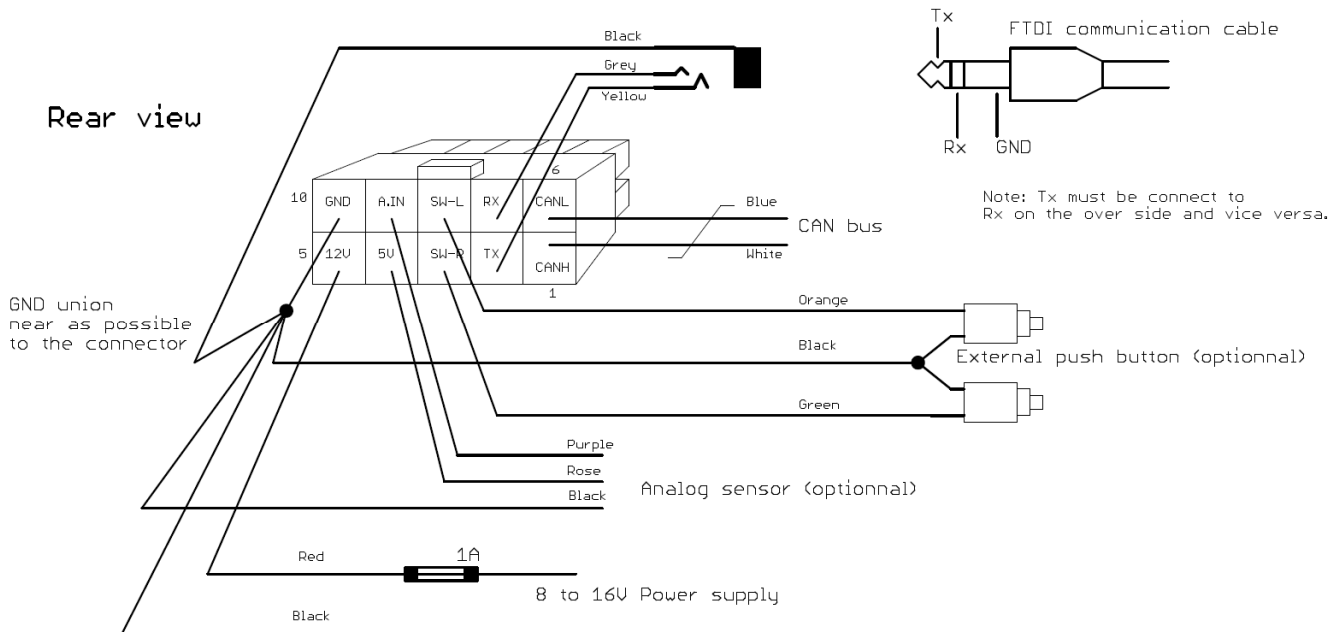

Note: Display Rx must be connected to FTDI Tx and Display Tx to FTDI Rx.

REMINDER ON THE CONNECTION OF A CAN-BUS

The modules connected in a CAN bus must be chained. This means that the pair of twisted wires of the differential line joining CAN H and CAN L have to go from one module to another and then to the last.

A load of 120 ohms must be present at each end of the chain, previously have to consult the technical documentation of each module to determine, depending on the presence or absence of this load, if the module must be at the start / finish or in the middle of the chain.

If the list of modules provided contains just a load of 120 Ohm, the user can add a second by plugging a resistance of 120 Ohm 5% 0.25 W at the other end of the chain.

Correct chain

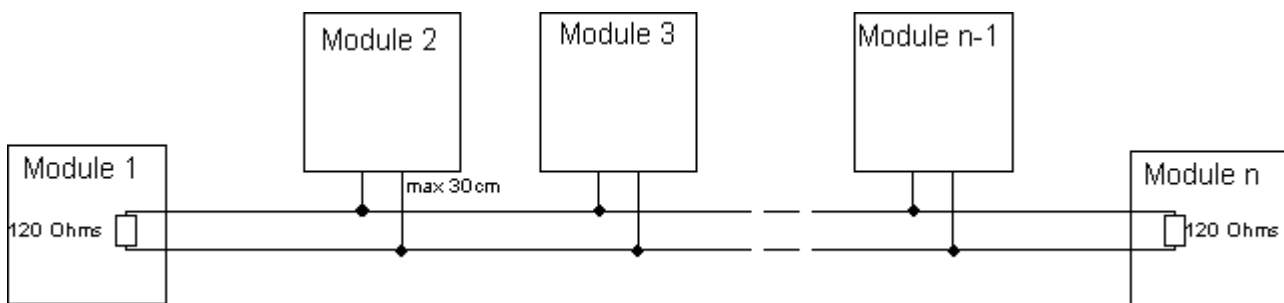

Incorrect chain

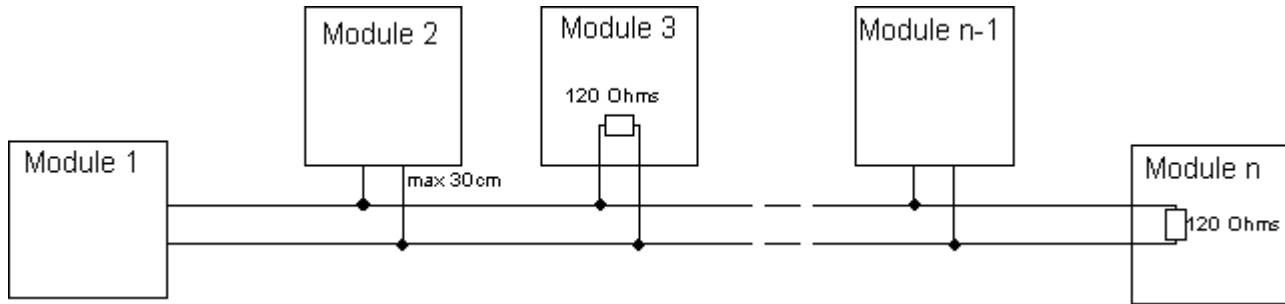

The controller lambda DigiLSU does not have this 120 ohm resistance. Therefore semi-finished wiring has a double line for connecting the CANbus to the output of the connector, and allows its insertion easily into the chain of modules.

FRONT PANEL DESCRIPTION

Front panel have a light sensor for automatic brightness trimming. Two sensitive zones below the four digit replace the both DC4D57 switches. It is important to not touch the front panel when DC4D52 is switching on.



CHOICE OF FUNCTIONING

Richness can be read on either the analog input or via CAN. In the latter case, a DigiLSU must be connected to the display and set up correctly (see details of the setup).

If no DigiLSU is detected, the display will take by default the richness on the analog input. If a DigiLSU is detected, the richness information from CAN take priority leaving the analog input inoperative.

MENU DESCRIPTION

During initialization, all segments of the four digits and the all sixteen LEDs must be turned on. After displaying the brand, a reminder of the selected channel and led scale is displayed.

From normal display, a short push on one of the two buttons indicates the selected channel. A succession of short push will scroll channels in one direction or the other depending on the pressed pushbutton. A delay of 2.5 seconds without user action will return to the normal display.

Channels availables and order :

Canal	Texte affiché	Description
Richesse	“rch”	Richness with 3 decimales
Lambda	“lbd”	Lambda (1/Richness) with 3 décimales
O2	“o2”	Oxygene ratio with 2 décimales
AFR	“AFr”	Air/fuel ratio with one decimale (stoichiometrique value must be adjusted with PC)
Volt	“uolt”	mV richness value
Canal 5	“Uin”	Analog input after conversion
Canal CAN 1	“Ch 1”	First CAN channel (user defined)
Canal CAN 2	“Ch 2”	Second CAN channel (user defined)
Canal CAN 3	“Ch 3”	Third CAN channel (user defined)
Canal CAN 4	“Ch 4”	Fourth CAN channel (user defined)
Vbat	“Ubat”	Battery voltage (interne)
Temps d'utilisation	“tine”	Using time

From normal display, long push on one of the two buttons to enter into the menu. If the right button is pressed, the menu starts with a maximum values menu, if it is the left push the menu will be show bargraph type.

Each long push scroll to the next menu in one direction or the other depending on the pressed pushbutton. There is no rotation. The end/beginning of menu reached, a long push does not wrap to the beginning/end.

The delay of 2.5 seconds without user action will return to the normal display. On each menu, a short push on the buttons scrolls through the options for each of them. The table below lists the available options and the menus for each.

Menu	Texte affiché	Description
Max Values	« HiGh »	Show maximum values
	« Clr »	Clear maximum values
Brightness	« Auto »	Automatic brightness ajustement
	« . »	Minimum brightness
	« . _ »	Medium brightness
	« . _ = »	High brightness
Baregraph scale	« . _ = ≡ »	Maximum brightness
	« GAS »	Bargraph scale for gasoline engine
Bargraphe mode	« diE »	Bargraph scale for diesel engine
	« dot »	Dot mode for baregraph
	« bAr »	Bar mode for baregraph

SHOW MAX VALUES

If the "High" menu is activated, the display will flash indicating that the displayed values are the maximum values recorded since the last reset. It is possible to scroll through the channels for see each maximum value.

To perform the reset, enter the "High" menu and press the right button to select the "Clr" (Clear) function. Returning to the normal display, the maximum values will be reset.

PUSH LOCK

You can lock the buttons. To do this, press the right button and the left button while holding the right and press them until the message "LOCD" (locked = locked) appears.

To unlock, simply do the same until you see the message "Unlo" (= unlocked unlocked).

ERRORS

Analog mode (using analog input as lambda input)

The analog input must be between 100mV and 4900mV to be considered valid. Outside this range, an error is enabled.

In the case of displaying a CAN channel, an error is detected if the corresponding message has not been received for 2 seconds.

Code erreur affiché	Erreur sur entrée Vin	Erreur sur réception CAN
Err1	X	
Err2		X
Err3	X	X

CAN Mode (using DigiLSU)

CAN mode using DigiLSU, errors will be displayed with the exception of warm up condition where the message "HEAt" will be displayed.

Ex : « Er0b » means that the controller is in warm up mode but the probe is disconnected and consequently its temperature is too cold.

The error code have 255 possible combinations, it is recommended to connect to DigiLSU and consult its diagnosis flags .

Warm Up
Open Circuit
Short Circuit
Probe Temp.
Power GND
Vgnd
VBat
Vs
CAN ok

Relation LED , tension, valeur de richesse

The A / F value depending on the stoichiometric ratio, it was decided to not show it on the following table. However, it can be calculated.

A / F = stoichiometric value x Lambda
 Or A / F = value Stoichiometric / Wealth.

These two tables below provide evidence of the difference between the two scales of bargraph. Indeed, it is a normal petrol engine working wealth of 1.12 to 1.20 (depending on whether atmospheric or turbocharged), while a diesel engine will have its less than richness 1.

Gasoline scale (« GAS »)

Vout (mV)	4702	3729	3288	2879	2686	2500	2382	2263	2146	2029	1838	1725	1540	1184	850	541
Richesse	0,000	0,400	0,600	0,800	0,900	1,000	1,030	1,060	1,090	1,120	1,170	1,200	1,250	1,350	1,450	1,550
Lambda	INF	2,50	1,67	1,25	1,11	1,00	0,97	0,94	0,92	0,89	0,85	0,83	0,80	0,74	0,69	0,65
O2 (%)	20,90%	12,20%	8,00%	4,00%	2,00%	0,00%	-0,60%	-1,20%	-1,80%	-2,30%	-3,30%	-3,90%	-4,80%	-6,70%	-8,60%	-10,40%

Diesel scale (< diE >)

Vout (mV)	4702	4449	4201	3961	3729	3505	3288	3079	2879	2781	2686	2592	2500	1914	1360	541
Richesse	0,000	0,100	0,200	0,300	0,400	0,500	0,600	0,700	0,800	0,850	0,900	0,950	1,000	1,150	1,300	1,550
Lambda	INF	10,00	5,00	3,33	2,50	2,00	1,67	1,43	1,25	1,18	1,11	1,05	1,00	0,87	0,77	0,65
O2 (%)	20,90%	18,70%	16,50%	14,40%	12,20%	10,10%	8,00%	6,00%	4,00%	3,00%	2,00%	1,00%	0,00%	-2,90%	-5,80%	-10,40%

LED BARGRAPHE MODE

The LEDs can be displayed in two different ways, bar or dot. In the first case ("bAr") all the LEDs from the left to the operating point will be on. On dot mode ("dot"), only two LEDs around the operating point will be lit.